

**R9 EVE OVERHANG**

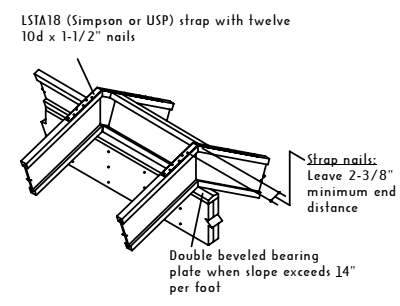

**R14 RIDGE DETAIL**

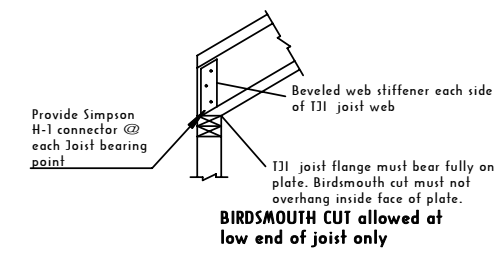

**BC ROOF JOIST @ BEARING WALL**

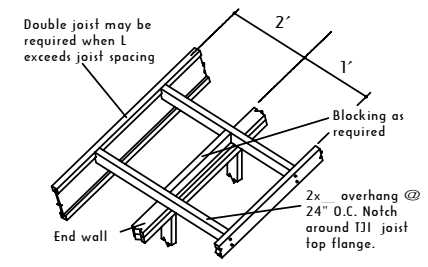

**O GABLE END OVERHANG**

**1**  
**5** TYPICAL SECTION  
Scale 1/2" = 1'-0"